

maskin mekano

VSIH T7

MOBILE VSI CRUSHING PLANT



High-end crushed products

Demand for highly processed crushing products with high and consistent quality is growing steadily. That is why Maskin Mekano launches an easy-to-move VSI crusher on high jacking legs.

The VSIH T7 is part of Maskin Mekano's new modular range, which is characterized by flexibility, safety and electric operation. The machine is a conveyor in/conveyor out machine but also has an on-board closed circuit conveyor that makes it compatible with Maskin Mekano's final screen SH 1503, but it can also be docked with a variety of other three-deck screening plants on the market. The machine has sockets for interlocking and connecting emergency stop loops to connecting machines in the process.

CRUSHER



VSI

WEIGHT



26.000

TRANSPORT



Trailer

CONSUMPTION



250 kWh

SET UP TIME



15 minutes





Crushing plant on high jacking legs

The VSIH T7 is a modern application designed for the specific requirements of VSI crushing. The plant features the reliable and proven VSI crusher by South African Techroq. Safety of operation, superior spare parts logistics and electrical drive provide outstanding productivity and low operating costs.

The VSI cubisator

Techroq VSI crushers are utilised for crushing the complete range of minerals, ores and rocks. Crushing can be controlled by adjusting rotor size and speed, screen mesh size, cascade ratio and cavity ring or feed gradation. The unique crushing action breaks corners off particles, providing cube shaped particles.

The Techroq VSI are distinctive among all other vertical shaft impactors for their pure rock-on-rock principle. Techroq's rock-on-rock crusher pumps dry stone at high velocity, launching an uninterrupted rock stream into a stone lined crushing chamber. The rock lined rotor accelerates the feeding rate into the machine, with materials discharged into the crushing chamber at high velocity - up to 85 meters (275 feet) per second. While replenishing the rock lining, the crushing and grinding cycle of rock-on-rock is maintained by this process.

Serving as ideal third and fourth stage crushing machines, Techroq VSI crushers combine high velocity impact crushing with high pressure attrition, to produce high levels of cubical products.

Stockpiling

The VSIH T7 is a conveyor in/conveyor out machine but also has an on-board closed circuit conveyor. Folding is performed without any twisting of belts and without any manual handling, which reduces set-up time. All drum motors are cambered and gummed.

Chassis

The VSIH T7 is a strong construction of welded girders designed to minimize vibrations during operation without making the machine unnecessarily heavy. The chassis is fitted with four sturdy hydraulic lifting legs which means that the operation height can easily be adjusted to fit the other units in the application. The lifting legs are also essential for loading and un-loading the machine on the trailer, and they are folded for transport so that the width does not exceed 3.0 metres. For towing on site there is a lifting hook and wheels in the rear.

The VSIH T7 is equipped with sturdy and safe catwalks around the crusher reached via foldable stairs with railings.

Electrical drive

The VSIH T7 is electrically driven, like all Maskin Mekano plants. Electrical drive provides low operating costs and reduces environmental and noise impact.

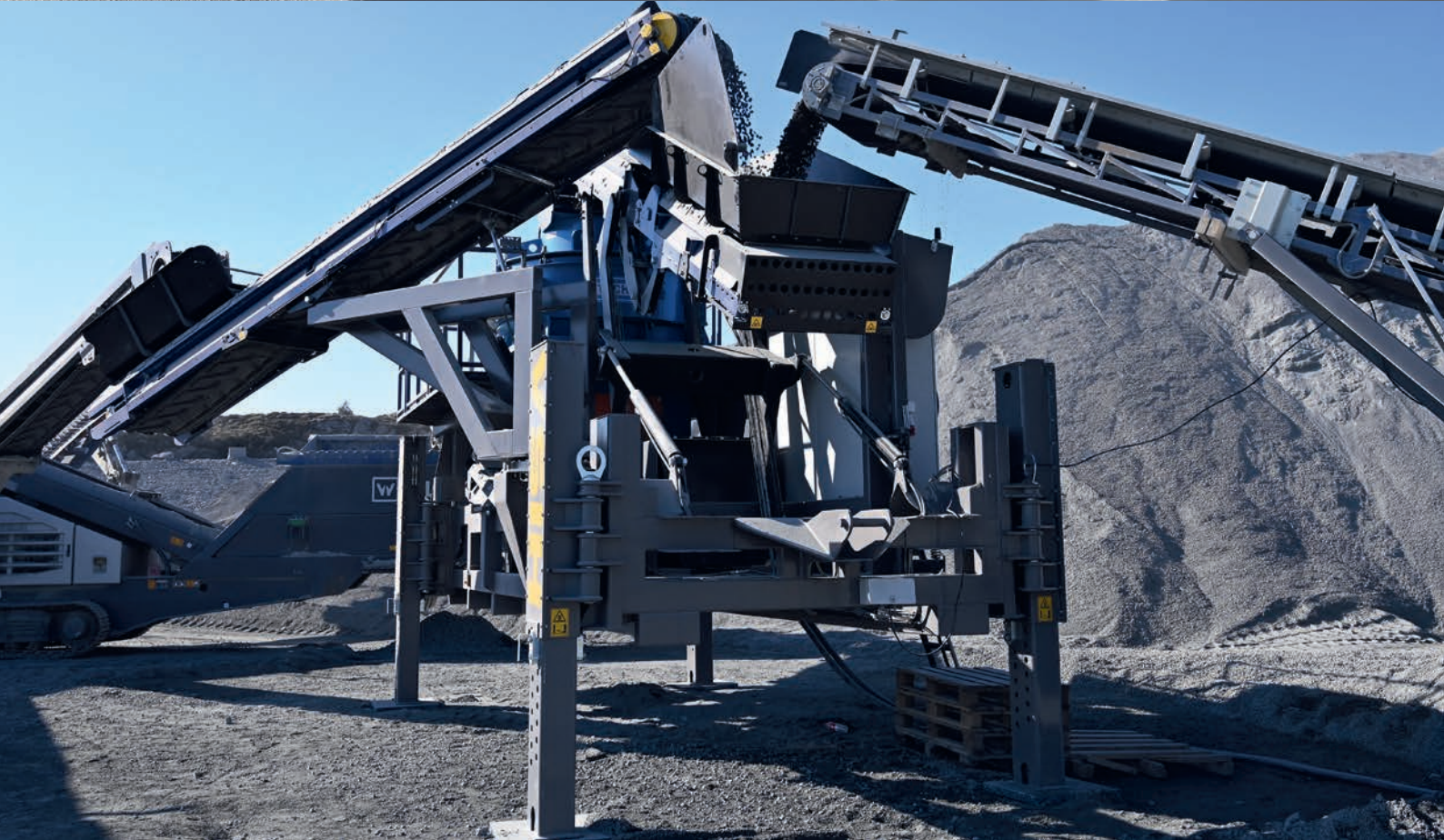

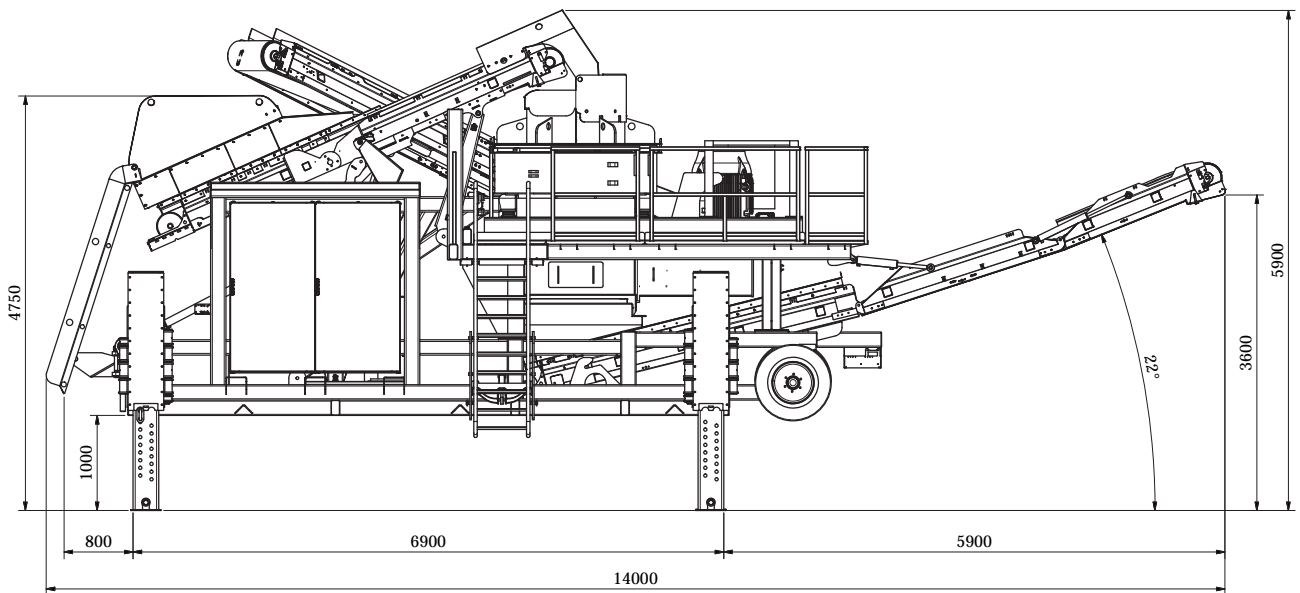
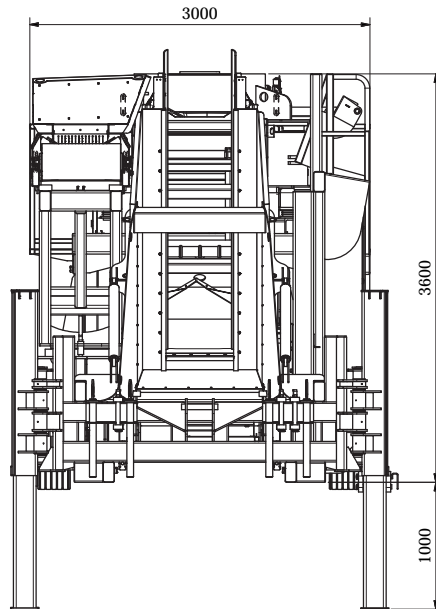
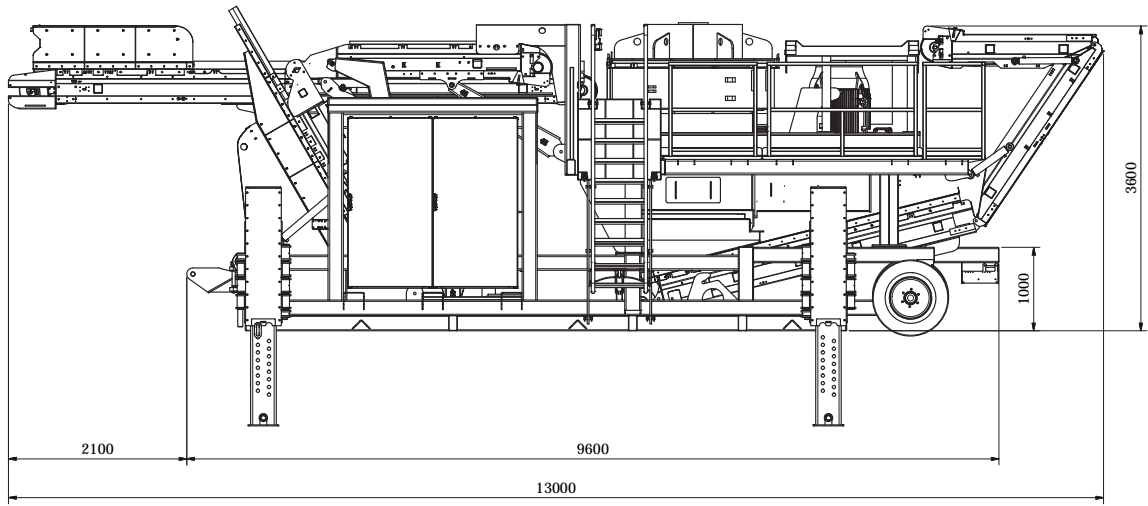

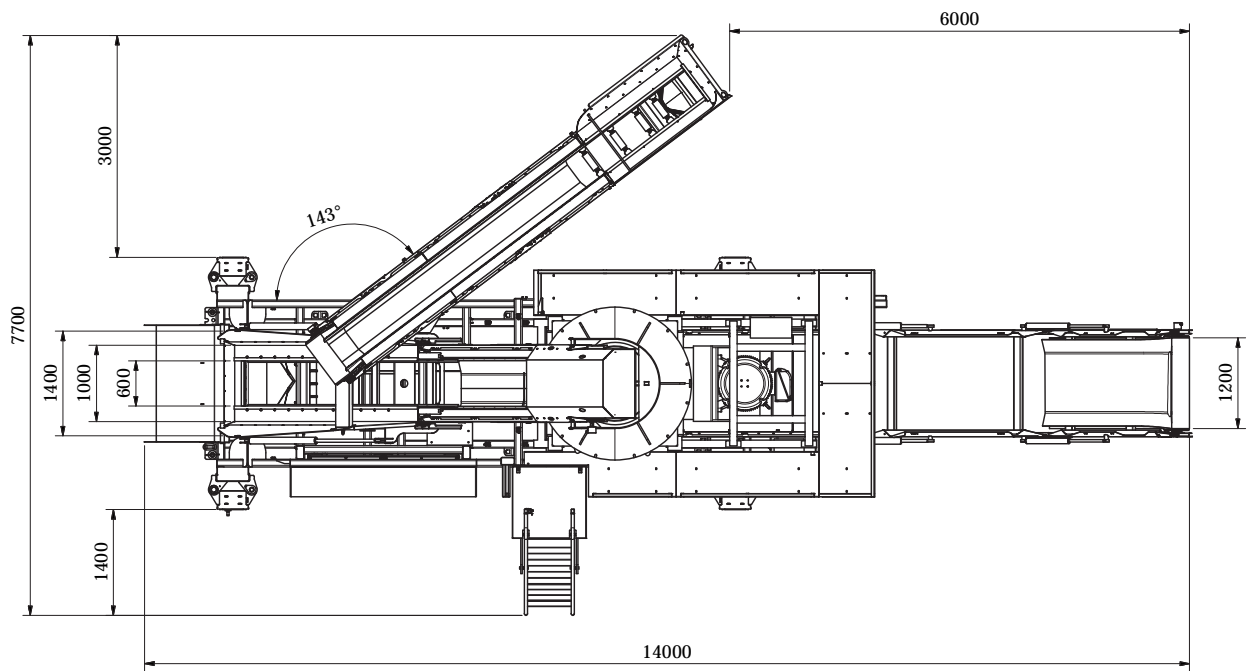
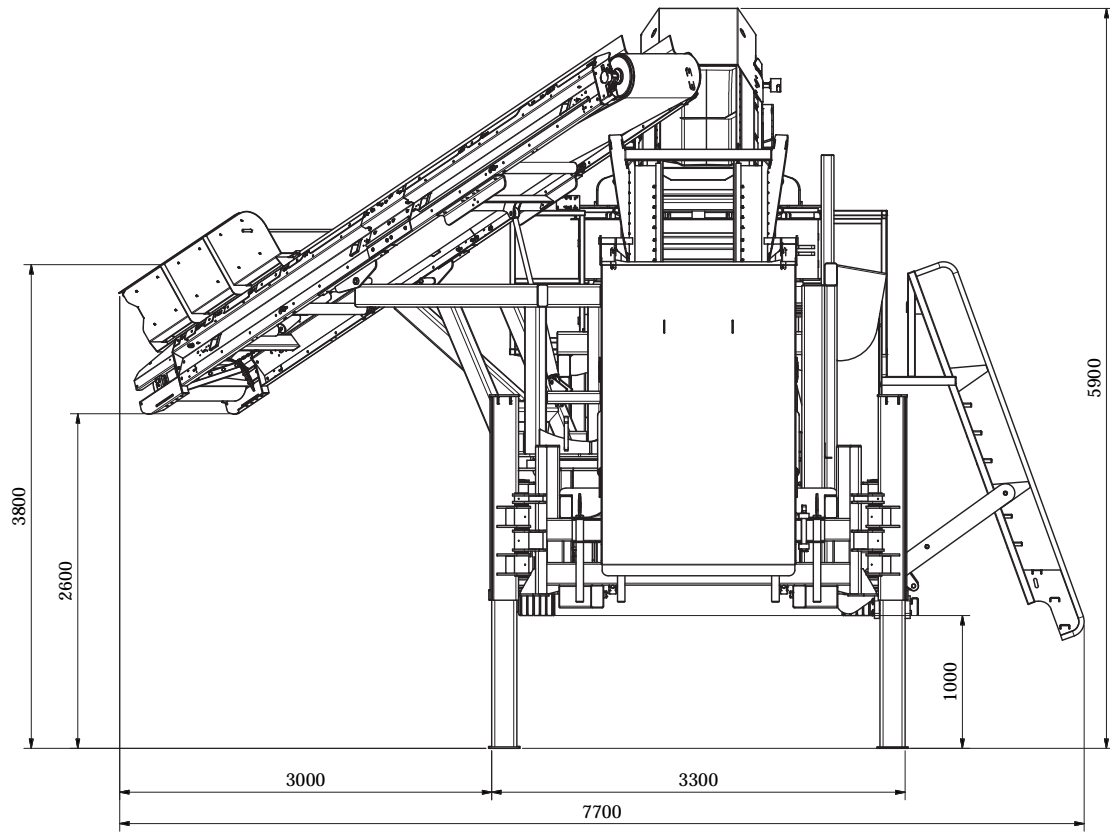

Technical Specification VSIH T7

<i>Transport Length</i>	13.0 m
<i>Transport Width</i>	3.0 m
<i>Transport Height</i>	3.6 m
<i>Machine Weight</i>	approx 26 tonnes, depending on equipment
<i>Cubisator</i>	Capacity about 200 tonnes/hour when feeding a material of <50 mm Mounted on a vibrationfree frame 840 Multi 5 Port STD QR Drop In Rotor, vibration-switch, frequency controller, manual rotor feed control, safety interlock, service tool kit, rotor lifting kit, automatic grease system, 250 kW electric motor mounted on cubisator
<i>Feeding conveyor Crusher</i>	Belt width 800 mm Length 4.9 m Electric drum motor 5.5 kW
<i>Closed circuit conveyor</i>	Belt width 650 mm Length 6.5 m Electric drum motor 4.0 kW
<i>Fines conveyor</i>	Belt width 1200 mm Length 8.5 m Electric drum motor 5.5 kW
<i>Electric equipment</i>	Distribution box mounted on chassis. Push button for sequence start 10" touch screen for starting of motors separately 7" touch screen for monitoring and adjusting rotation speed Emergency stops on chassis, conveyors and distribution box Speed monitors on all conveyors Monitored circuits for safety relay. Safety interlock
<i>Hydraulic equipment</i>	Hydraulic aggregate for folding of the conveyors and stairs and lifting of hydraulic legs Motor 4.0 kW
<i>Wheel- and towing device</i>	Hook and wheels for towing on site Chassis optimized for trailer transports Hydraulic jacking legs for production mode

Our policy is one of continuous improvement and we reserve the right to change the detailed specification of our products at any time without prior notice.

ADVANTAGES OF ALL OUR PLANTS:

CARBON FOOTPRINT



Electric drive
OR low emissions

VIBRATIONFREE



The Vibroblock
concept

SCREEN CAPACITY



Aggressive stroke

NOISE IMPACT



Very low

OPERATOR SAFETY



Protection according
to regulations

OVERVIEW



Touchscreen in
electrical cabinet

MADE IN SWEDEN



maskin mekano

Address: Maskin Mekano AB, Box 9083, 550 09 Jönköping, SWEDEN,

Phone: + 46 36 31 74 00

E-mail: info@maskinmekano.se

www.en.maskinmekano.se